

# LL15.70

**CAPACITY 230 KG**

(2 persons 80x2=160 kg + tool box 70 kg)

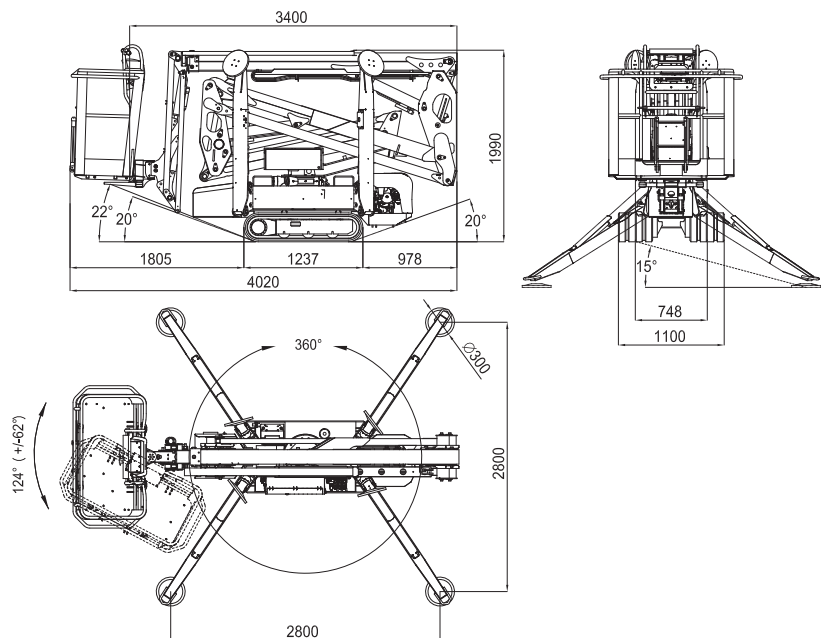
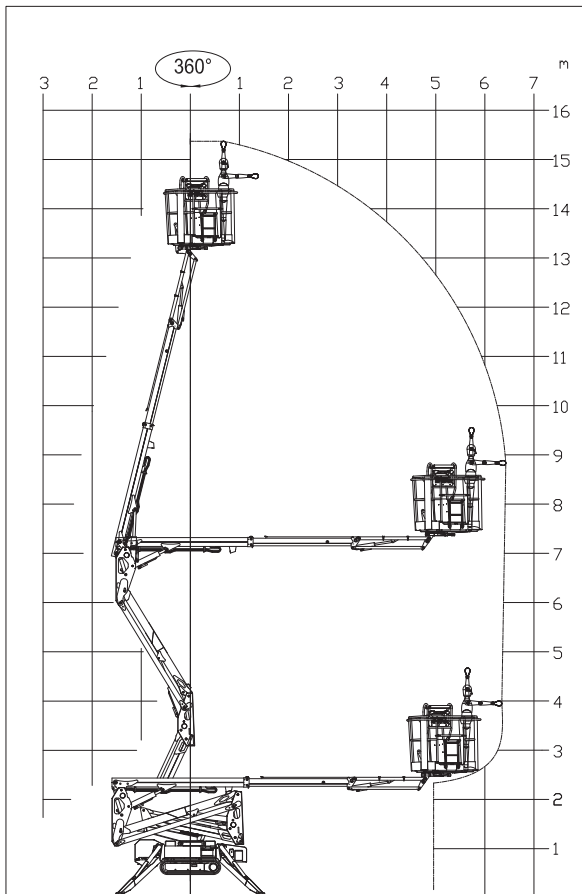

15,40 m



1.335 x 690 x h. 1.100 mm



2.800 x 2.800 mm



6,60 m



124° (+/-62°)



Automatic set up system IIS std.



4,02 m



16° / 28,7%



Remote control



3,40 m



748 - 1.100 mm



GPRS-GPS

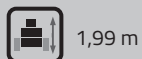

1,99 m



1.670 daN - 2,36 daN/cm<sup>2</sup>



R.A.H.M.



Lithium-ion battery pack  
3,6 kWh  
Optional



**PETROL ENGINE**

Brand.....HONDA  
 Type .....GX390  
 Pistons no. and displacement.....  
 ..... single-cylinder 389 cm<sup>3</sup>  
 Max gross power .....  
 11,7HP - 8,7 kW @ 3600 rpm (GX390)  
 Electrical start..... 12 volt

**DIESEL ENGINE**

Brand..... HATZ  
 Type ..... 1B40 - HD Autorev  
 Pistons no. and displacement.....  
 ..... single-cylinder 462 cm<sup>3</sup>  
 Max gross power .....  
 ..... 10 HP - 7,5 kW @ 3600 rpm  
 Electrical start..... 12 volt

**LITHIUM-ION SYSTEM**

Lithium-ion powered ..... 3,6 kWh  
 Onboard battery charger .....  
 ..... 220V 50Hz or 110V 50Hz  
 Autonomy..... 4-5 h  
 Recharge time on flat batteries .....  
 ..... .4 h (indicative)  
 Recharge time to 80% on flat batteries.  
 ..... 2 h (indicative)

**HYDRAULIC PUMPS**

Electric motor ..... no. 2 gear pumps

**TRACKED UNDERCARRIAGE**

Track tensioner ..... grease-filled  
 Rollers no. per side ..... 3 + slide

Translation speed with 2<sup>nd</sup> auto2speed:

- thermal engine ..... 1,4 - 2,6 km/h  
 - lithium system..... 0,4 - 0,8 - 1,6 km/h

WEIGHT MACHINE petrol engine..... 1940 kg  
 WEIGHT MACHINE diesel engine..... 1960 kg  
 WEIGHT MACHINE lithium system ..... 1992 kg

MAX WIND SPEED ..... 12,5 m/s